

## CARATTERISTICHE TECNICHE

Portata Massima (con carico uniformemente distribuito)	<b>200 kg</b>
Alimentazione	12 v
Velocità di uscita	1,2 sec

Portata Massima  
**200 kg**  
 carico uniformemente distribuito

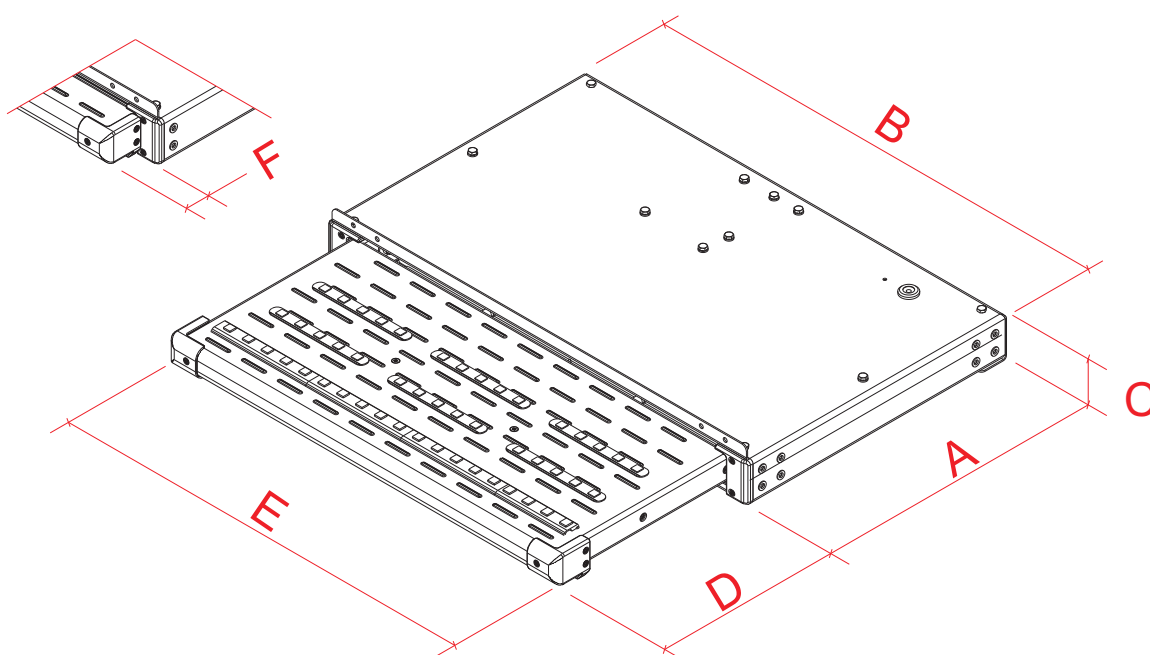
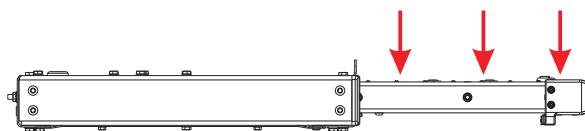

## CARATTERISTICHE DIMENSIONALI

Modello	A	B	C	D	E	F	Peso Kg
<b>STEP P35-E45</b>	355	550	67	280	450	63	23
<b>STEP P35-E60</b>	355	700	67	280	600	63	26
<b>STEP P35-E80</b>	355	900	67	280	800	63	30
<b>STEP P35-E110</b>	355	1200	67	280	1100	63	36

Modello	A	B	C	D	E	F	Peso Kg
<b>STEP P39-E60</b>	385	770	67	305	600	63	27
<b>STEP P39-E80</b>	385	900	67	305	800	63	31
<b>STEP P39-E110</b>	385	1200	67	305	1100	63	37